



# Instruction Manual

Analog Dry Block Heaters

Digital Dry Block Heaters



## TABLE OF CONTENTS

Package Contents	1
Warranty	1
Installation	2
Maintenance & Servicing	2
Environmental Conditions	2
Equipment Disposal	2
Safety Instructions	3
Standards & Regulations	3
Analog Dry Block Heater	4-6
Digital Control Panel	7
Digital Dry Block Heater	8-14
Troubleshooting	14
Replacement Parts	15-16

### PACKAGE CONTENTS

Dry Block Heater  
92" (234cm) detachable power cord  
Instruction manual  
Warranty card

### WARRANTY

Manufacturer warrants this product to be free from defects in material and workmanship when used under normal conditions for two (2) years. Please complete and return the enclosed warranty card. For your reference, make a note of the serial number, date of purchase and supplier here.

Serial No.: \_\_\_\_\_ Date of Purchase: \_\_\_\_\_

Supplier: \_\_\_\_\_

## INSTALLATION

---

Upon receiving the VWR Dry Block Heater, check to ensure that no damage has occurred in shipment. It is important that any damage that occurred in transport is detected at the time of unpacking. If you do find such damage the carrier must be notified immediately.

After unpacking, place the Dry Block Heater on a level bench or table, away from explosive vapors. Ensure that the surface on which the unit is placed will withstand typical heat produced by the unit and place the unit a minimum of 6" (15.2cm) from vertical surfaces. Always place the unit on a sturdy work surface.

The Dry Block Heater is supplied with a power cord that is inserted into the IEC connector on the back of the unit first, then it can be plugged into a properly grounded outlet. The 120V unit plugs into a 120 volt, 50/60 Hz source. The 230V unit plugs into a 230 volt, 50/60 Hz source.

It is necessary to fill the Dry Block Heater well(s) with modular heating blocks because empty block locations will affect performance. Place filled tubes in modular block(s), then place the modular block(s) into the Dry Block Heater well(s).

## MAINTENANCE & SERVICING

---

The Dry Block Heater is built for long, trouble-free, dependable service. No lubrication or other technical user maintenance is required. It needs no user maintenance beyond keeping the surfaces clean. The unit should be given the care normally required for any electrical appliance. Avoid wetting or unnecessary exposure to fumes. Spills should be removed promptly after the unit has cooled down. **DO NOT** use a cleaning agent or solvent on the front panel which is abrasive or harmful to plastics, nor one which is flammable. Always ensure the power is disconnected from the unit prior to any cleaning. If the unit ever requires service, contact your VWR representative.

## ENVIRONMENTAL CONDITIONS

---

**Operating Conditions:** Indoor use only.

Temperature:	18 to 33°C (64 to 91°F)
Humidity:	20% to 80% relative humidity, non-condensing
Altitude:	0 to 6,562 ft (2000 M) above sea level

**Non-Operating Storage:**

Temperature:	-20 to 65°C (-4 to 149°F)
Humidity:	20% to 80% relative humidity, non-condensing

Installation Category II and Pollution Degree 2 in accordance with IEC 664.

## EQUIPMENT DISPOSAL

---



This equipment must not be disposed of with unsorted waste. It is your responsibility to correctly dispose of the equipment at life-cycle-end by handing it over to an authorized facility for separate collection and recycling. It is also your responsibility to decontaminate the equipment in case of biological, chemical and/or radiological contamination, so as to protect the persons involved in the disposal and recycling of the equipment from health hazards.

For more information about where you can drop off your waste of equipment, please contact your local dealer from whom you originally purchased this equipment. By doing so, you will help to conserve natural and environmental resources and you will ensure that your equipment is recycled in a manner that protects human health.

## SAFETY INSTRUCTIONS

---

Please read the entire instruction manual before operating the Dry Block Heater.



**WARNING! DO NOT** use the Dry Block Heater in a hazardous atmosphere or with hazardous materials for which the unit was not designed. Also, the user should be aware that the protection provided by the equipment may be impaired if used with accessories not provided or recommended by the manufacturer, or used in a manner not specified by the manufacturer.

Always operate unit on a level surface for best performance and maximum safety.



**CAUTION!** To avoid electrical shock, completely cut off power to the unit by disconnecting the power cord from the unit or unplug from the wall outlet. Disconnect unit from the power supply prior to maintenance and servicing.

Spills should be removed promptly, after the unit has cooled down. **DO NOT** immerse the unit for cleaning. **DO NOT** operate the unit if it shows signs of electrical or mechanical damage.

The Dry Block Heaters are designed to be operated in dry conditions. **DO NOT** put water, oil or other fluids in the wells of the units. The chamber that the modular heating blocks and baths sit in is not designed to be filled with liquid or other fluids. **DO NOT** place anything other than the appropriate heating block(s) in this cavity.



**CAUTION!** Dry Block Heaters are not explosion proof. Use caution when unit is on or when heating volatile materials.



Earth Ground - Protective Conductor Terminal



Alternating Current

## STANDARDS & REGULATIONS

---

The manufacturer hereby declares under its sole responsibility that the construction of this product conforms in accordance with the following standards:

### Safety standards:

IEC 61010-1	Safety requirements for electrical equipment for measurement, control and laboratory use. Part I: General Requirements.
IEC 61010-2-010	Part II: Particular requirements for laboratory equipment for the heating of materials.
UL Std. No. 61010-1	

### EMC standards:

EN6100-3-2	EN61000-3-3
EN61000-4-5	FCC-B
EN61000-4-4	EN55022-A
EN61000-4-2	EN61000-4-3
EN61000-4-11	EN61000-4-6
EN45501	

### Associated EU guidelines:

EMC directive 2004/108/EC  
LVD directive 2006/95/EC

## ANALOG DRY BLOCK HEATER SPECIFICATIONS - 120 VOLT

	1 Block	2 Block	3 Block	4 Block	6 Block
<b>Dimensions (L x W x H):</b>	12.4 x 8 x 3.5" (31.5 x 20.3 x 8.9cm)	15.4 x 8 x 3.5" (39.1 x 20.3 x 8.9cm)	18.4 x 8 x 3.5" (46.7 x 20.3 x 8.9cm)	16.9 x 8 x 3.5" (42.9 x 20.3 x 8.9cm)	20.9 x 8 x 3.5" (53.1 x 20.3 x 8.9cm)
<b>Electrical 120V 50/60 Hz:</b>	0.9 amps, 110 watts	1.7 amps, 210 watts	1.7 amps, 210 watts	2.6 amps, 310 watts	3.4 amps, 410 watts
<b>Fuses:</b>	5mm x 20mm, 5 amp quick acting				
<b>Temperature low range:</b>	ambient +5°C to 100°C				
<b>Temperature high range:</b>	75°C to 150°C				
<b>Stability @ 37°C:</b>	+/-1°C	+/-1.5°C	+/-2°C	+/-2°C	+/-2°C
<b>Uniformity w/in the block @ 37°C:</b>	+/-0.1°C				
<b>Uniformity across similar blocks @ 37°C:</b>	N/A	+/-0.1°C	+/-0.15°C	+/-0.2°C	+/-0.3°C
<b>Stability @ 60°C:</b>	+/-3°C	+/-4°C	+/-4°C	+/-5°C	+/-5°C
<b>Uniformity w/in the block @ 60°C:</b>	+/-0.6°C				
<b>Uniformity across similar blocks @ 60°C:</b>	N/A	+/-0.8°C	+/-1°C	+/-1.2°C	+/-1.4°C
<b>Heat-up time to 100°C:</b>	45 min.	50 min.	60 min.	70 min.	75 min.
<b>Controls:</b>	rocker switch heat indicator light low temperature knob, variable 1 to 10 dial markings high temperature knob, variable 1 to 10 dial markings				
<b>Ship weight:</b>	5.8lbs (2.6kg)	6.4lbs (2.9kg)	8lbs (3.6kg)	8.5lbs (3.9kg)	10lbs (4.5kg)

## ANALOG DRY BLOCK HEATER SPECIFICATIONS - 230 VOLT

	1 Block	2 Block	3 Block	4 Block	6 Block
<b>Cat. No. with Euro plug</b>	460-3249	460-3252	460-3255	460-3258	460-3261
<b>Cat. No. with UK plug</b>	460-3250	460-3253	460-3256	460-3259	460-3262
<b>Cat. No. with Swiss plug</b>	460-3251	460-3254	460-3257	460-3260	460-3263
<b>Dimensions (L x W x H):</b>	31.5 x 20.3 x 8.9cm	39.1 x 20.3 x 8.9cm	46.7 x 20.3 x 8.9cm	42.9 x 20.3 x 8.9cm	53.1 x 20.3 x 8.9cm
<b>Electrical 230V 50/60 Hz:</b>	0.5 amps, 110 watts	0.9 amps, 210 watts	0.9 amps, 210 watts	1.3 amps, 310 watts	1.7 amps, 410 watts
<b>Fuses:</b>	5mm x 20mm, 5 amp quick acting				
<b>Temperature low range:</b>	ambient +5°C to 100°C				
<b>Temperature high range:</b>	75°C to 150°C				
<b>Stability @ 37°C:</b>	+/-1.5°C	+/-2°C	+/-2°C	+/-2.5°C	+/-2.5°C
<b>Uniformity w/in the block @ 37°C:</b>	+/-0.4°C				
<b>Uniformity across similar blocks @ 37°C:</b>	N/A	+/-0.5°C	+/-0.6°C	+/-0.7°C	+/-0.9°C
<b>Stability @ 60°C:</b>	+/-3°C	+/-4°C	+/-4°C	+/-5°C	+/-5°C
<b>Uniformity w/in the block @ 60°C:</b>	+/-0.6°C				
<b>Uniformity across similar blocks @ 60°C:</b>	N/A	+/-0.8°C	+/-1°C	+/-1.2°C	+/-1.4°C
<b>Heat-up time to 100°C:</b>	45 min.	50 min.	60 min.	70 min.	75 min.
<b>Controls:</b>	rocker switch heat indicator light low temperature knob, variable 1 to 10 dial markings high temperature knob, variable 1 to 10 dial markings				
<b>Ship weight:</b>	2.6kg	2.9kg	3.6kg	3.9kg	4.5kg

## ANALOG DRY BLOCK HEATER OPERATING INSTRUCTIONS

These multi-purpose units are ideal for incubation and activation of cultures, enzyme reactions, immunoassays, melting/boiling points and a wide variety of other laboratory procedures.

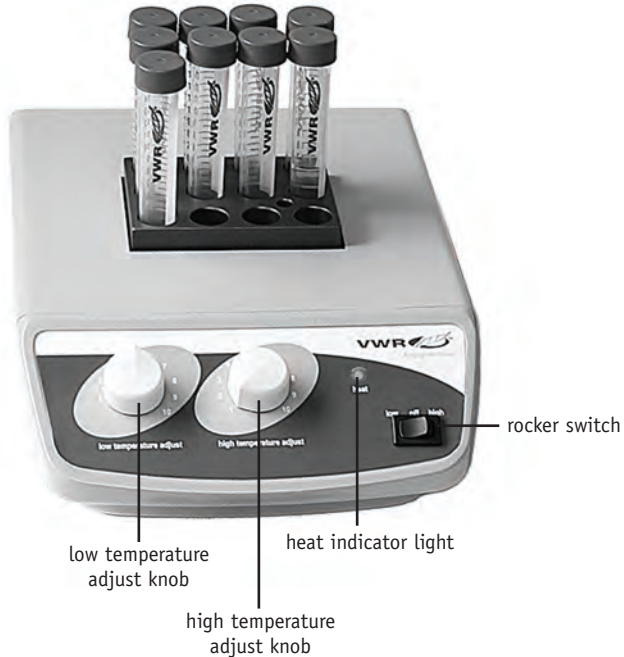

*VWR Analog 1 Block Heater with modular block and tubes*

1. Switch the three (3) position rocker power switch from the center off position to the low range or high range position as desired. The controls are divided into two separate heating ranges, both thermostats having graduations to assist in setting the desired temperatures. The left hand 'low temperature adjust' controls from slightly above ambient to approximately 100°C. The right hand 'high temperature adjust' controls from approximately 75°C to 150°C.
2. The rocker switch has a center off position and is used to select the desired operating range. When operating at the point where the two thermostats overlap in temperature range, the proper thermostat must be chosen for the task being performed. Move the power switch to the desired operating range and turn the matching range temperature control knob clockwise to increase the temperature within the range selected. The heat indicator light will illuminate during the operation of the heater.
3. The temperature may be verified by placing a calibrated thermometer in the test solution or by insertion in the modular block thermometer well provided. This hole fits regular glass bulb thermometers or small diameter digital probes. Due to air currents and radiation losses, the temperature in the test solution will be lower than the temperature in the block itself. For the most accurate readings a thermometer should be placed in a sample test tube with solution matching the samples being tested. If the temperature is too high or too low, adjust clockwise to increase temperature, counter-clockwise to decrease temperature. Slight adjustments will usually suffice to correct the temperature setting. When the heat indicator light flashes on and off intermittently, check the temperature again. Allow sufficient time for the temperature to stabilize before re-adjusting. This procedure should be followed until the desired temperature is reached.

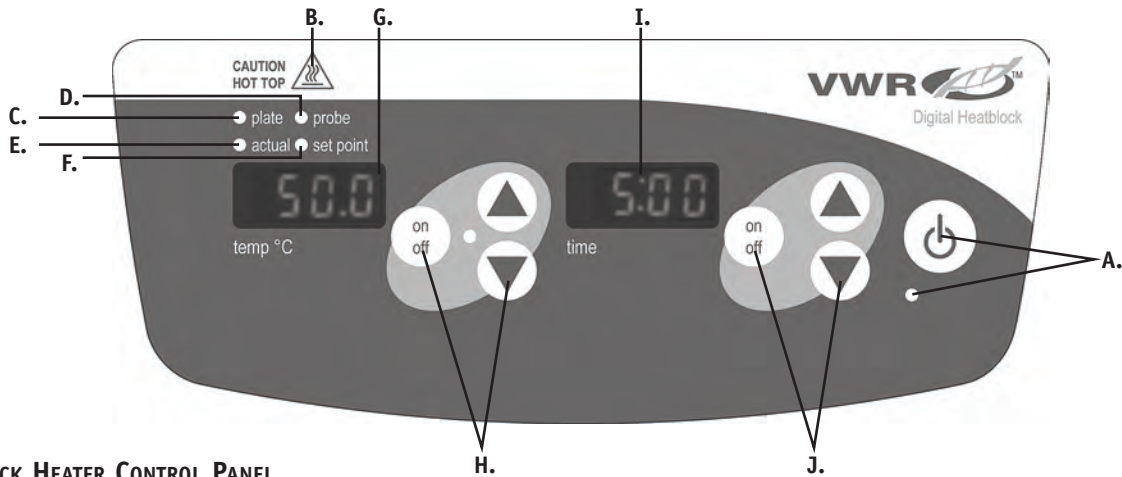

## DIGITAL DRY BLOCK HEATER CONTROL PANEL

The front panel of the Dry Block Heater contains all the controls and displays needed to operate the unit.

**A. Standby button/standby indicator light:** The standby indicator light will illuminate when the unit is plugged in. The unit will be in standby mode. Press the standby button to start the temperature and time functions. The standby indicator light will shut off. Press the standby button again and the unit will once again be in standby mode.

**B. Caution hot top indicator light:** Illuminates when the plate temperature is above 40°C (104°F).

**C. Plate indicator light:** Illuminates when the optional external RTD probe is not being used. The temperature displayed is the plate temperature.

**D. Probe indicator light:** Illuminates when the optional external RTD probe is plugged in. The temperature displayed is the probe temperature, NOT the plate temperature.

**E. Actual indicator light:** Illuminates when the temperature displayed is the actual temperature of the plate/RTD probe.

**F. Set-point indicator light:** Illuminates when the set-point temperature is displayed.

**G. Temperature display:** Displays the actual/set-point temperatures in conjunction with the actual/set-point indicator lights. **H.** Up/down arrows for set-point control. On/off button starts/stops the heating function.

**I. Time display:** Displays accumulated time (continuous mode) or how much time is remaining (timed mode). The display range is from 0 to 9,999 minutes in one (1) second increments. The display will indicate minutes and seconds until the timer reaches 99 minutes and 59 seconds (99:59), then the display will automatically display minutes up to 9,999. **J.** Up/down arrows for set-point control. On/off button starts/stops the timer function.



**DIGITAL DRY BLOCK HEATER SPECIFICATIONS - 120 VOLT**

	<b>1 Block</b>	<b>2 Block</b>	<b>3 Block</b>	<b>4 Block</b>	<b>6 Block</b>
<b>Dimensions (L x W x H):</b>	12.4 x 8 x 3.5" (31.5 x 20.3 x 8.9cm)	15.4 x 8 x 3.5" (39.1 x 20.3 x 8.9cm)	18.4 x 8 x 3.5" (46.7 x 20.3 x 8.9cm)	16.9 x 8 x 3.5" (42.9 x 20.3 x 8.9cm)	20.9 x 8 x 3.5" (53.1 x 20.3 x 8.9cm)
<b>Electrical 120V 50/60 Hz:</b>	0.9 amps, 110 watts	1.7 amps, 210 watts	1.7 amps, 210 watts	2.6 amps, 310 watts	3.4 amps, 410 watts
<b>Fuses:</b>	5mm x 20mm, 5 amp quick acting				
<b>Temperature range:</b>	ambient +5°C to 120°C				
<b>Stability @ 37°C:</b>	+/-0.1°C				
<b>Uniformity w/in the block @ 37°C:</b>	+/-0.1°C				
<b>Uniformity across similar blocks @ 37°C:</b>	N/A	+/-0.1°C	+/-0.15°C	+/-0.2°C	+/-0.3°C
<b>Stability @ 60°C:</b>	+/-0.4°C				
<b>Uniformity w/in the block @ 60°C:</b>	+/-0.4°C				
<b>Uniformity across similar blocks @ 60°C:</b>	N/A	+/-0.5°C	+/-0.7°C	+/-0.8°C	+/-1°C
<b>Heat-up time to 100°C:</b>	45 min.	50 min.	55 min.	60 min.	65 min.
<b>Controls:</b>	see page 7				
<b>Ship weight:</b>	5.8lbs (2.6kg)	6.4lbs (2.9kg)	8lbs (3.6kg)	8.5lbs (3.9kg)	10lbs (4.5kg)

## DIGITAL DRY BLOCK HEATER SPECIFICATIONS - 230 VOLT

	1 Block	2 Block	3 Block	4 Block	6 Block
<b>Cat. No. with Euro plug</b>	460-3264	460-3267	460-3270	460-3273	460-3276
<b>Cat. No. with UK plug</b>	460-3265	460-3268	460-3271	460-3274	460-3277
<b>Cat. No. with Swiss plug</b>	460-3266	460-3269	460-3272	460-3275	460-3278
<b>Dimensions (L x W x H):</b>	31.5 x 20.3 x 8.9cm	39.1 x 20.3 x 8.9cm	46.7 x 20.3 x 8.9cm	42.9 x 20.3 x 8.9cm	53.1 x 20.3 x 8.9cm
<b>Electrical 230V 50/60 Hz:</b>	0.5 amps, 110 watts	0.9 amps, 210 watts	0.9 amps, 210 watts	1.3 amps, 310 watts	1.7 amps, 410 watts
<b>Fuses:</b>	5mm x 20mm, 5 amp quick acting				
<b>Temperature range:</b>	ambient +5°C to 120°C				
<b>Stability @ 37°C:</b>	+/-0.2°C				
<b>Uniformity w/in the block @ 37°C:</b>	+/-0.2°C				
<b>Uniformity across similar blocks @ 37°C:</b>	N/A	+/-0.3°C	+/-0.4°C	+/-0.5°C	+/-0.6°C
<b>Stability @ 60°C:</b>	+/-0.4°C				
<b>Uniformity w/in the block @ 60°C:</b>	+/-0.4°C				
<b>Uniformity across similar blocks @ 60°C:</b>	N/A	+/-0.5°C	+/-0.7°C	+/-0.8°C	+/-1°C
<b>Heat-up time to 100°C:</b>	45 min.	50 min.	55 min.	60 min.	65 min.
<b>Controls:</b>	see page 7				
<b>Ship weight:</b>	2.6kg	2.9kg	3.6kg	3.9kg	4.5kg

## DIGITAL DRY BLOCK HEATER OPERATING INSTRUCTIONS

Designed for applications that require repeatable results and superior temperature stability. These multi-purpose units are ideal for incubation and activation of cultures, enzyme reactions, immunoassays, melting/boiling points, and a wide variety of other laboratory procedures.

For best performance, the Dry Block Heater should be used in a stable environment. The unit's environment should have no air currents, drafts or temperature changes and it cannot be placed in direct sunlight. The unit requires a stable electrical supply that is free of voltage fluctuations. An unstable environment will adversely affect the performance of the unit. For example, even minor air drafts or temperature changes will adversely affect the unit's ability to maintain a stable temperature.

### 1. Getting ready:

- a. When using the external RTD probe, plug the RTD probe into the three (3) pin DIN connector at the back of the unit and place the thermometer portion in the thermometer well of the modular block. When using multiple blocks, place the RTD probe in the front right modular block.
-  b. Press the standby button to change the unit from standby mode. The temperature display, time display and probe indicator light will illuminate. When not using the RTD probe, the plate indicator light will illuminate. The temperature display will alternate between the actual and set-point temperatures.

### 2. Setting temperature:

- a. Press the up/down arrows to the right of the temperature display until you reach the desired temperature. Holding down either the up or down arrow will cause the set temperature to change rapidly, a single pressing of either key will move the set temperature by 0.1°C. When you release the button, the display will blink off and then on, indicating the new set temperature has been accepted. Once the set-point has been programmed and the keys are not being pressed, press the on/off button to the

right of the temperature display to activate the heating function. A green indicator light will illuminate next to the on/off button indicating the heating function is on. The actual and set-point indicator lights will alternate between set and actual temperatures. There are three (3) audible beeps to indicate the set-point temperature has been reached.

- b. Set-point temperature adjustments can be made without interrupting heating using the up/down arrows to the right of the temperature display. After the change has been made and you release the button, the display will blink off and then on indicating the new set temperature has been accepted.
- c. To stop heating, press the on/off button to the right of the temperature display.
- d. Allow time for the temperature to stabilize. The actual temperature displayed is the temperature at the bottom of the modular block or of the RTD probe. Once the displayed actual temperature agrees with the set temperature, several minutes should be allowed for the temperature to stabilize throughout the block evenly.

**Overshoot protection:** If the unit exceeds the set temperature by 10°C, the unit will automatically stop heating.

### 3. Setting timed mode: Programmed time.

- a. Press the up/down arrows to the right of the time display until you reach the desired time.
- b. Start this function by pressing the on/off button to the right of the time display, the unit will run for the selected time. When using the timer in conjunction with the heating function, when the time display reaches zero (0:00), five (5) audible beeps will indicate the time down function is complete. Both the time and heating functions will shut off automatically and the time display will default back to the set time. To repeat for the same time, simply depress the on/off button again.
- c. To interrupt an automatic timing cycle before it is completed, press the

on/off button to the right of the time display. The time display will flash until you resume the time function by pressing the on/off button again. This interrupt will not stop the heating function, the heating function will stop only when the timer reaches zero (0:00).

4. **Setting time to zero (0:00) and continuous mode:** Accumulated time.
  - a. Press and hold the on/off button to the right of the time display. After three (3) seconds, the display will indicate the previous set time.
  - b. Simultaneously press both the up and the down arrows, the display will indicate zero (0:00). The unit time is now set to zero (0:00) minutes. Alternately, you can use the up/down arrows to get to zero (0:00).
  - c. Press the on/off button to the right of the time display, the display will indicate actual running time. The up/down arrows will become inactive. To stop timer, press the on/off button again. **IMPORTANT:** This will not affect the heating function. Press the on/off button to the right of the heat display to interrupt the heating function.
  - d. To reset, press and hold the on/off button to the right of the time display. After three (3) seconds the display will indicate the previous set time, which was zero (0:00).

#### 5. Turning unit off:

- a. To turn the unit off, press the standby button, the temperature and time displays will be blank, the standby indicator light will turn on.

### CALIBRATION PROCEDURE

This procedure is used to fine tune and calibrate the block temperature at a specific temperature setting. It will only be active without an external temperature probe connected. This process may be repeated for up to three (3) separate set-points. If a fourth calibration set-point is entered, the first set-point entered will be overwritten.

1. Turn unit on.
2. Set desired temperature.

3. Stabilize twenty (20) minutes or more, measuring the block temperature with a calibrated precision instrument or thermometer.
4. Press and hold standby button, then press the temperature up button once. The unit will beep two (2) times, confirming calibration mode. The display will now be flashing.
5. Press the temperature up/down arrows until the display matches the temperature probe/thermometer.
6. Press standby button to exit calibration mode and return to normal heating.

This process may be repeated at the same set-point multiple times for fine tuning if desired.

The unit will now use the biased offset for that specific temperature setting and increase or decrease temperature accordingly to bring the block temperature to set temperature. The decimal point of the display will flash to indicate a biased offset is being used. All other temperature settings will use the standard internal calibration. This offset will be stored in memory and retained until reset.

#### *To restore unit to factory setting:*

Press and hold standby button while pressing the temperature down button once. The reset will be confirmed with two (2) beeps. Press the standby button to exit calibration mode and return to normal heating.

### BEEPER PREFERENCE

To silence beeper operation (except for error codes), with the unit in standby mode, press and hold the time on/off button and press the standby button. To restore normal beeper operation, remove AC power to unit for 10 seconds and then restore. Alternately, you may have to turn the unit on and press and hold the standby button and press and hold the time on/off button simultaneously.

## **MODULAR HEATING BLOCKS AND SAMPLES**

Only VWR Modular Heating Blocks are to be used in the Dry Block Heaters.

1. Select the proper blocks that will be a precise fit for the tubes, plates, or vials that you will be using for your application.
2. Only plastic or glass tubes, plates, or vials are to be used in the Modular Heating Blocks. Metal vessels will adversely affect the temperature performance of the unit. Metal vessels will dissipate too much heat into the air, thus adversely affecting the temperature readings of the unit.
3. Blocks need to be in all positions on the unit so the heating plate is not exposed to the environment.
4. To ensure proper heating, the tubes, plates, or vials that are used must be the correct size for the Modular Heating Block. The tubes, plates or vials must fit securely in the hole with no air gaps and maintain as much contact as possible with the wall of the block. This will ensure good thermal contact between the Modular Heating Block and the tube, plate or vial you are using for your application.
5. For proper heating, the fluid level within your tube, plate or vial should not exceed the height of the Modular Heating Block. If your application requires the fluid level to be above the height of the block, then a temperature cover is recommended.
6. When using a temperature measuring device in a sample, the end of the probe should be placed at the bottom of the sample and the height of the liquid should not exceed the height of the Modular Heating Block. Ensure that your temperature measuring device is designed for immersion in liquids.
7. Contact your VWR representative for information on ordering Modular Heating Blocks and other Dry Block Heater accessories.

## **OPTIONAL EXTERNAL RTD PROBE KIT (FOR DIGITAL UNITS)**

1. If your application requires a high level of accuracy, the optional external

RTD probe should be used with the Dry Block Heater.

2. Follow the 'Operating Instructions' for the proper installation of the optional external RTD probe. With the RTD probe plugged into the back of the unit, place the thermometer portion in the thermometer well of the Modular Heating Block. With the external RTD probe in place, the RTD probe is now driving the displayed temperature setting for the operation of the unit, not the heating plate of the unit. Once the optional external RTD probe is properly installed, the probe indicator LED above the temperature display will be illuminated.

## **TEMPERATURE TESTING**

1. To ensure good thermal conductivity, select the proper Modular Heating Block for your application. Select the proper tubes or vials which are the proper size for the Modular Heating Block. Close contact, with no air gaps, must be maintained between the walls of the Modular Heating Block well and the sides of the tubes or vials.
2. Fill the tubes or vials so that the fluid level does not rise above the top surface of the Modular Heating Block.
3. Select a temperature measuring device that is designed for immersion in liquids. Place your calibrated temperature measuring device in one of the samples so it reaches the bottom of the tube or vial. Once the temperature measuring device is placed in the fluid sample, ensure the fluid level is still below the top surface of the Modular Heating Block.
4. Set the desired temperature on the unit, allow the unit to reach this temperature, and let the unit stabilize for an additional twenty (20) minutes or more before taking any temperature readings.
5. The temperature can also be tested by utilizing the thermometer hole in the Modular Heating Block. A calibrated temperature measuring device can be inserted into the thermometer hole where there is a snug fit and close contact between the walls of the block and the tempera-

ture device. The temperature device must reach the bottom of this hole with no air gaps. Follow the procedure above for allowing the unit to reach temperature and stabilize before taking any temperature readings.

6. If the measured temperature on your temperature measuring device does not match the actual temperature on the display of the unit (for Digital units only), then the single point calibration procedure can be used. By doing this, the unit will now be more accurate at that set-point for your specific application.

### **STABILITY TESTING**

1. The manufacturer has performed temperature stability tests on Dry Block Heaters. The manufacturer used calibrated temperature measuring devices for the stability tests. Units were set-up with the proper number of Modular Heating Blocks so the heater plates were not exposed to the environment. A calibrated temperature measuring device was inserted into the thermometer well of one block on each unit. The testing temperature was set, the units were allowed to heat up and stabilize for a minimum of twenty (20) minutes and then temperature readings were recorded at regular intervals for four (4) hours. These tests confirmed the temperature stability of the units.
2. The recommended procedure for testing the unit's stability is as follows:
  - a. Set-up the unit in a stable environment.
  - b. Set-up the unit with the proper number of Modular Heating Blocks for the unit. Place a calibrated temperature measuring device into the thermometer well of the Modular Heating Block. The temperature device should have a snug fit with no air gaps in the thermometer well. Set the temperature of the unit. Allow the unit to reach temperature and stabilize for twenty (20) minutes or more and then take temperature readings for stability.
  - c. Another method to test for stability is to set up the unit with the proper number of Modular Heating Blocks and then place the proper fitting tubes or vials into the blocks. Fill the tubes or vials with liquid, where

the liquid level is lower than the top surface of the Modular Heating Block. Use a calibrated temperature measuring device that is designed for immersion in liquids, and place the temperature probe in the bottom of one of the tubes or vials in one block. Set the temperature of the unit. Allow the unit to reach temperature and stabilize for twenty (20) minutes or more and then take temperature readings for stability. Please note the characteristics of the liquid used for the test and the fit of the tube or vial in the Modular Heating Block can affect the results of a stability test for the Dry Block Heaters. Tubes and vials must be the proper size for the Modular Heating Block so there is a secure fit with no air gaps to ensure good thermal contact.

### **UNIFORMITY TESTING**

1. The manufacturer has performed uniformity tests on Dry Block Heaters to ensure even heating across the entire heater plate. For the one block heaters, the manufacturer used a specially designed Modular Heating Block with five (5) temperature holes. Five independent calibrated temperature measuring devices were used during the test. For multiple block units, Modular Heating Blocks were placed in all positions to cover the entire heating plate and then an independent calibrated temperature measuring device was used in the thermometer well of each block. For all tests, the tip of the temperature measuring device was an exact fit for the temperature well in the Modular Heating Block with no air gaps. The temperature was set and the units were allowed to heat up and stabilize for twenty (20) minutes or more. Readings were then taken at regular intervals to monitor the temperature uniformity for four (4) hours. These tests were repeated after rotating the temperature measuring devices to different thermometer well positions to confirm the temperature uniformity of the units.
2. The recommended procedure for testing the unit's temperature uniformity is as follows:
  - a. Set-up the unit in a stable environment.
  - b. Set-up the unit with the proper number of Modular Heating Blocks to

cover the entire heating plate. Then set up the blocks with the proper fitting tubes or vials. Place liquid samples in tubes or vials where the liquid level is lower than the height of the top surface of the Modular Heating Block.

- c. Select multiple calibrated temperature measuring devices that are designed for immersion in liquids. Use these temperature measuring devices at the same time across various positions in the Modular Heating Block(s). Place the temperature probes in the bottom of several of the filled tubes or vials. Ensure the liquid levels in the tubes or vials with the temperature probes does not rise above the height of the top surface of the Modular Heating Block.
- d. Set the temperature of the unit. Allow the unit to reach temperature and stabilize for twenty (20) minutes or more and then take temperature readings from all the temperature devices to test for temperature uniformity.
- e. Please note the characteristics of the liquid used for the test and the fit of the tube or vial in the Modular Heating Block can affect the results of the uniformity test for the Dry Block Heaters. Tubes and vials must be the proper size for the Modular Heating Block so there is a secure fit with no air gaps to ensure good thermal contact.

## **TROUBLESHOOTING**

---

Error codes for digital units.

The following errors should **NOT** be addressed by the end user. Switch the unit off and contact your VWR representative for repairs.

### **Error Code**

### **Cause**

E01

faulty temperature sensor

E02

temperature sensor failure  
heating element failure

E03

### **Probe Errors**

probe not in thermometer well  
probe left on counter  
unit cannot reach set-point

Errors will cause heating function to cease. Timing functions will be unaffected.

## ANALOG DRY BLOCK HEATER REPLACEMENT PARTS

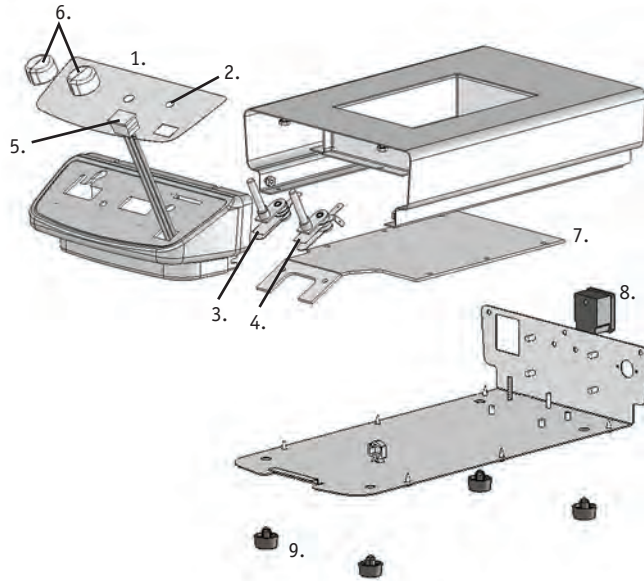

### ANALOG DRY BLOCK HEATERS

Description	120V	230V
1. Front panel overlay	349153-00	349153-00
2. Pilot lamp indicator	330015-00	330016-00
3. Thermostat, low	349201-00	349201-00
4. Thermostat, high	349202-00	349202-00
5. Rocker switch w-leads	349030-00	349030-00
6. Knob (2)	287010-00	287010-00
7. Heater assembly		
1 block	849310-00	849311-00
2 block	849312-00	849313-00
3 block	849314-00	849315-00
4 block	849316-00	849317-00
6 block	849318-00	849319-00
8. Power entry module	386122-00	386122-00
9. Rubber foot (4)	149023-00	149023-00

### POWER CORDS

Description	Part No.
120V US	330100-00
230V EURO	330101-00
230V UK	330102-00
230V SWISS	330103-00



## DIGITAL DRY BLOCK HEATER REPLACEMENT PARTS

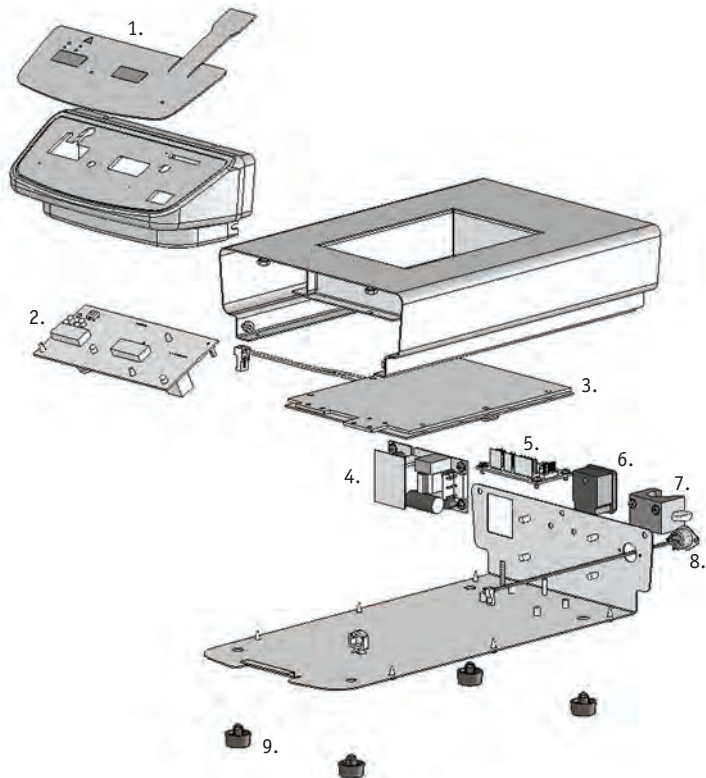

### DIGITAL DRY BLOCK HEATERS

Description	120V	230V
1. Membrane switch	349152-00	349152-00
2. Control board	349200-00	349200-00
3. Heater assembly 1 block	849300-00	849411-00
2 block	849302-00	849413-00
3 block	849304-00	849415-00
4 block	849306-00	849417-00
6 block	849308-00	849419-00
4. Power supply	349151-00	349151-00
5. Sensor board	349205-00	349205-00
6. Power entry module	349180-00	349180-00
7. Mounting bracket	230080-00	230080-00
8. RTD cable assembly	349164-00	349164-00
9. Rubber foot (4)	149023-00	149023-00

### POWER CORDS

Description	Part No.
120V US	330100-00
230V EURO	330101-00
230V UK	330102-00
230V SWISS	330103-00





---

MANUFACTURED BY:

**HENRY TROEMNER LLC**

201 Wolf Drive • PO Box 87 • Thorofare, NJ 08086-0087  
Phone: 856-686-1600 • Fax: 856-686-1601 • E-mail: [troemner@troemner.com](mailto:troemner@troemner.com)  
[www.troemner.com](http://www.troemner.com)

549009-00 REV (2 - 3/09)